

E a s t e r n  *A c c e n t s*[®]
WORKROOM



C.O.M. Drapery
Wholesale



Table of Contents

How To Order	4
Railroaded vs. Up the Roll Fabrics	6
How To Measure	7
Yardage Charts	12
Pricing Guide	18
Style Guides	20
Curtain Panels	24
Valances	26
Shower Curtain	28
Upgrade Information	30

How To Order

Creating products with customer's own material (C.O.M.) with Eastern Accents is fun and easy! Just follow these simple steps to get started:

1

Choose Product

Eastern Accents offers a variety of curtain panels and valances.

2

Choose Style

Eastern Accents offers 14 panel styles to choose from. There are also 14 styles of valances. Choose Length, Width, Fabrics, Lining, and Upgrades.

3

Choose Size, Fabrics, Closure, and Upgrades

A. Choose Size

Choose from any panel length and width within our yardage grid on page 10. Call for size information if the panel exceeds 196" bracket to bracket width or 132" length.

B. Choose Fabrics

Browse our deluxe binders or visit EasternAccents.com to select fabrics and trimmings for your custom draperies. You may combine both Eastern Accents and C.O.M. fabrics or solely use C.O.M. fabrics and trimmings in your product. Please note our yardage charts are based on 54" wide fabrics, 2.5 fullness, and 3.5" returns and overlaps. Contact Customer Service at 800.397.4556 for specific information on using wider or narrower fabrics.

FABRIC CONSISTENCY AND SUBSTITUTIONS: Fabrics offered by Eastern Accents may have variations in texture and color. We may substitute similar fabrics and trimmings if the originals are no longer available. Please visit EasternAccents.com for current fabric and trimming availability.

C. Choose Lining

Eastern Accents curtain panels include a standard 100% cotton medium-weight drapery lining, which may be removed or upgraded for a fee adjustment.

D. Add Upgrades (optional)

You may add upgrades such as lining, trimming, bands, a swagged cord, or buttons to pleats to your drapery panels and valances. For special requests please call for information.

E. Sign the Form

Once you have completed the worksheet, carefully review and sign it. Please note that custom items cannot be exchanged and are non-returnable and non-refundable.

4

Submit Your Order

After you have completed and signed your worksheet, email it to Custom@EasternAccents.com or fax it to 800.998.3278. Do not ship C.O.M. fabrics or trimmings prior to receiving an order confirmation number from Eastern Accents.

5

Receive Order Confirmation Number

Eastern Accents will review your order and email or fax you an order confirmation number.

6

Ship Fabrics and Trims

After receiving your order confirmation number, ship C.O.M. fabrics and trimmings to Eastern Accents with the order confirmation number and your company's name clearly marked on the package. The shipping address for C.O.M. fabrics and trimmings is:

Eastern Accents
Attn.: C.O.M. Department
3138 N. Tripp Avenue
Chicago, IL 60641

Note that Eastern Accents reserves the right to refuse any material or design not suited for production.

7

Production and Delivery

Lead time for C.O.M. orders is about 3-5 weeks after receipt of all C.O.M. materials.



Railroaded vs. Up the Roll Fabrics

Railroaded Fabrics

Fabric pattern or grain runs across the roll horizontally, from selvage to selvage.

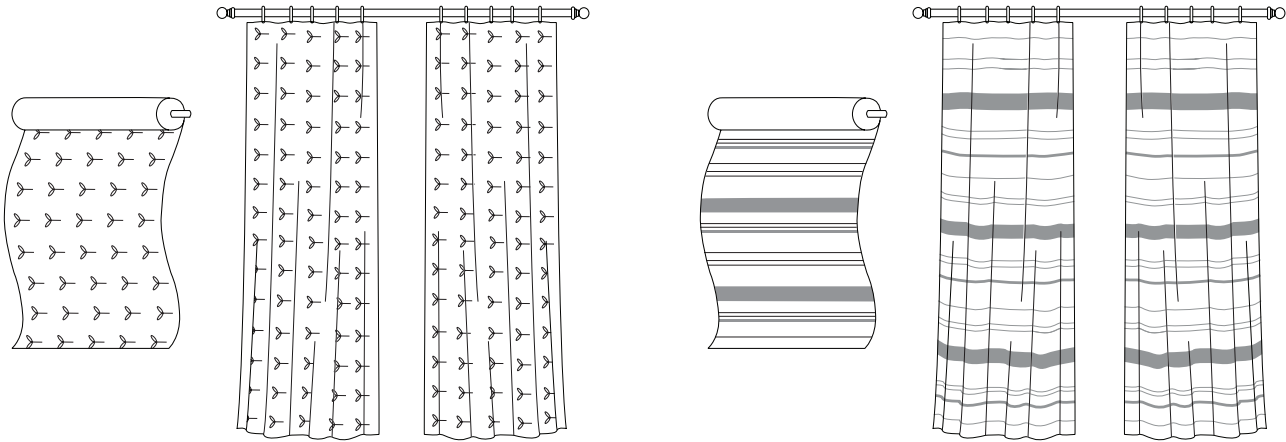

Railroaded fabrics for panels with a stripe pattern always run horizontally. For valances or partial trims, please specify the direction. The seams on your drapery will be adjusted according to the pattern direction you have chosen.

Up the Roll Fabrics

Fabric pattern or grain runs up the roll vertically, parallel to the selvages.

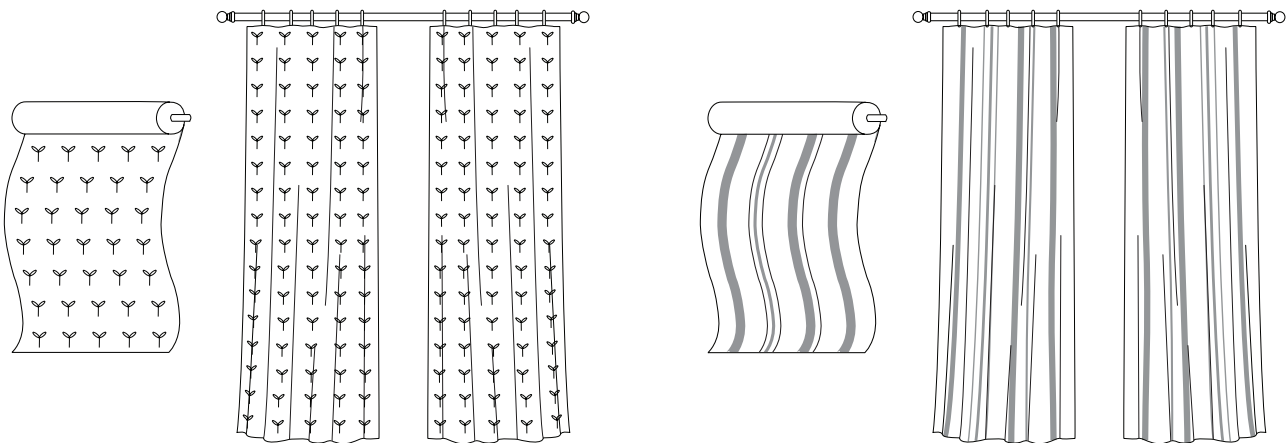

For Up the Roll fabrics with a stripe pattern, please specify whether you would like the pattern to run horizontally or vertically. The seams on your drapery will be adjusted according to the pattern direction you have chosen.

How To Measure

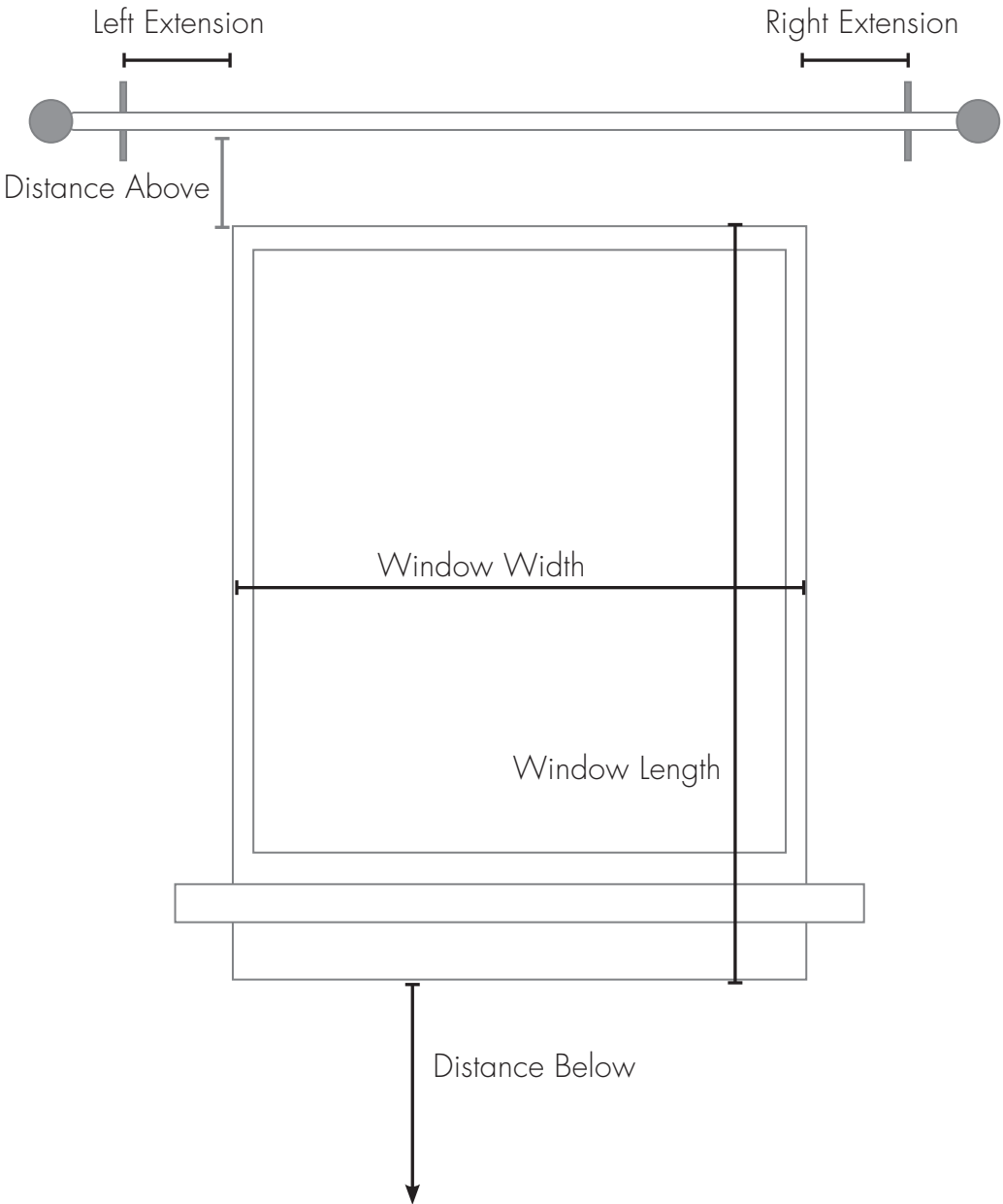

How To Measure Width

This guide will help you measure the width of your drapery. Use metal measuring tape (round up to the nearest inch) and follow the instructions below:

1

Choose either a **pair of panels** (split draw) or **single panel** (one way draw).

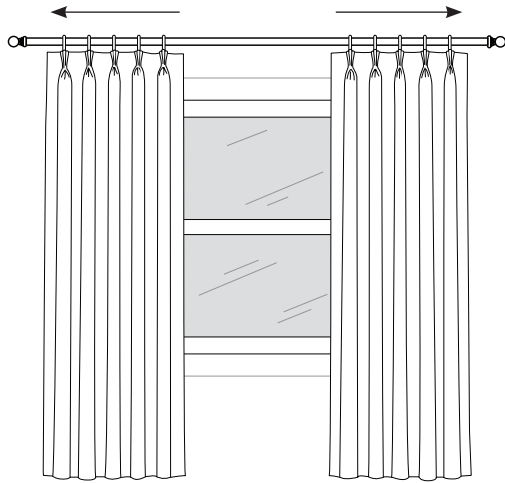

Pair of Panels (Split Draw)

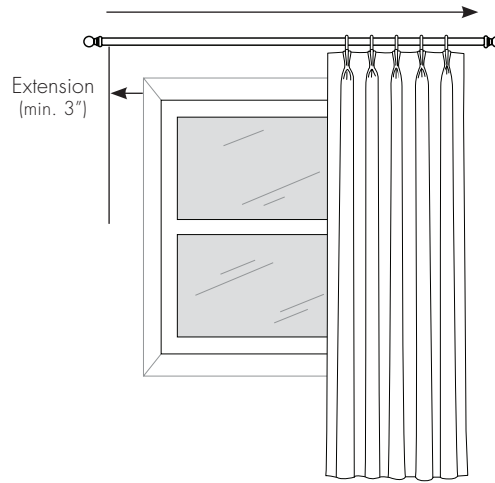

Single Panel (One Way Draw)

With pleated or non pleated panel, one width of fabric covers approximately 17" - 20" of space.

2

Determine return size. A return is when a panel returns to the wall. The standard for Eastern Accents panels is 3.5". When placing panels over sheers or other treatments you must increase the size of the return to cover all treatments. There should be approximately 3" to 3.5" between treatments so check to make sure your brackets have the correct projection and contact us for proper yardage requirements.

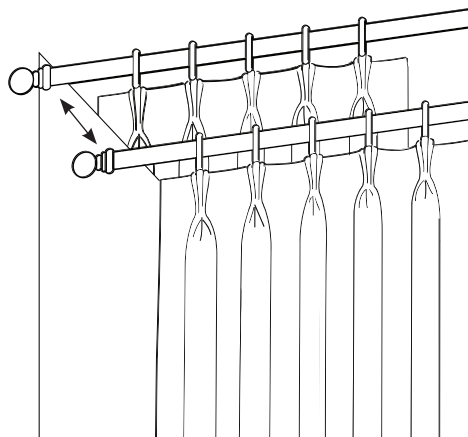

How To Measure Width

3 Determine stacking or bounce back:

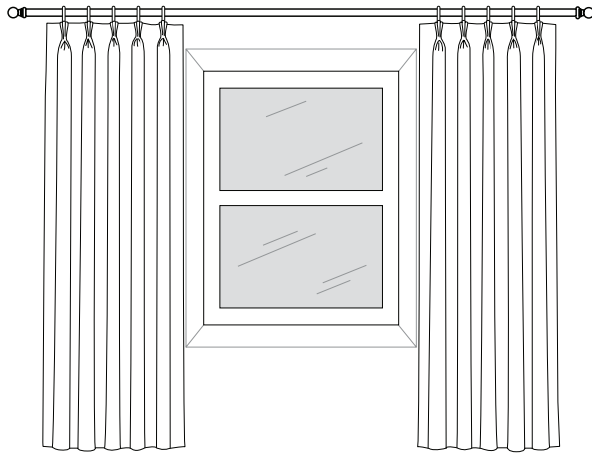

Stacking

To expose or clear more glass when panels are in the most open position, you will need more wall space or extension in the bracket to bracket measurement. One width of light to medium weight fabric stacks to approximately 11".

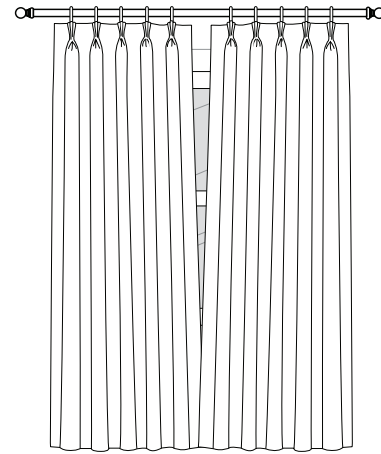

Bounce Back

When hanging pleated functional panels on a decorative rod and rings you may experience bounce back, where the panels won't stay together when closed. Consider adding 10% of your bracket to bracket measurement to finish width.

Finished Width Calculations

Single Stationary Panel

To help determine the size of your stationary panel, use chart below.*

Left Extension	Window Width	Right Extension	Bracket to Bracket	Divide by 4	Finished Width*
+	+	=	/	4 =	

*Use finished width to determine yardage requirement

Functional Panels (split draw)

Left Extension	Window Width	Right Extension	Bracket to Bracket	Return	Overlap	Overall Finished Width
+	+	=	+	L R	+ L R	=

Single Functional Panel (one way draw)

Left Extension	Window Width	Right Extension	Bracket to Bracket	Return	Overlap	Left or Right Stacking (facing window)	Finished Width
+	+	=	+	L or R	+	<input type="checkbox"/> L or <input type="checkbox"/> R	+

How To Measure Length

This guide will help you measure the length of your drapery. Use metal measuring tape (round up to the nearest inch) and follow the instructions below:

1

Determine drapery pole placement. Note that for high placement your bracket will dictate how close you can get to the ceiling and still be able to place the rod in the bracket. For low placement, if a center bracket is needed, the bracket will determine how high above the window frame your pole will sit.

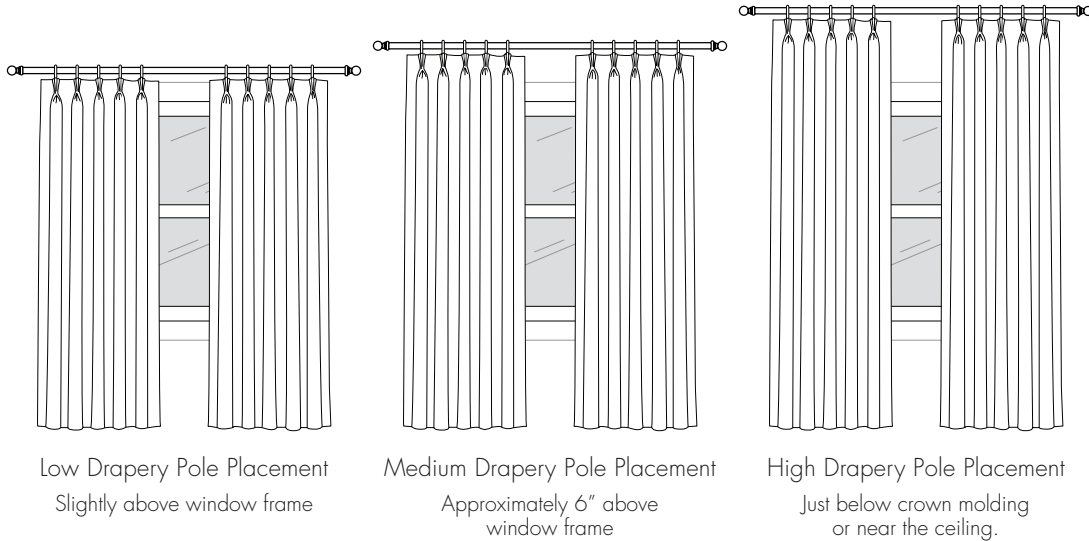

2

Determine header position.

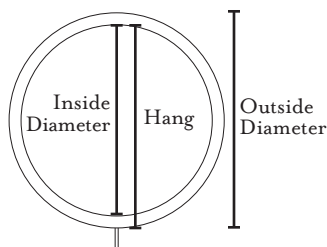
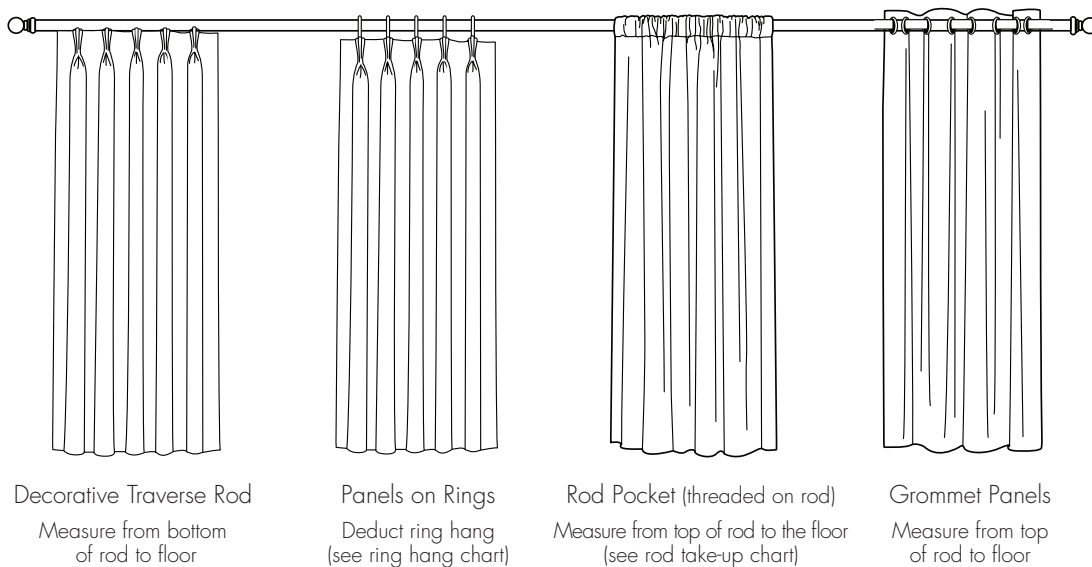

Ring Hang Chart	
EA Ring Type	Hang
Gemelina	3.5"
Metallique	2.25"

Rod Take-up Chart		
Rod	Take-up	Pocket Size
1 3/8"	1"	3"
2"	1.5"	4.5"
3"	2"	6.5"

How To Measure Length

3 Determine any extra length.

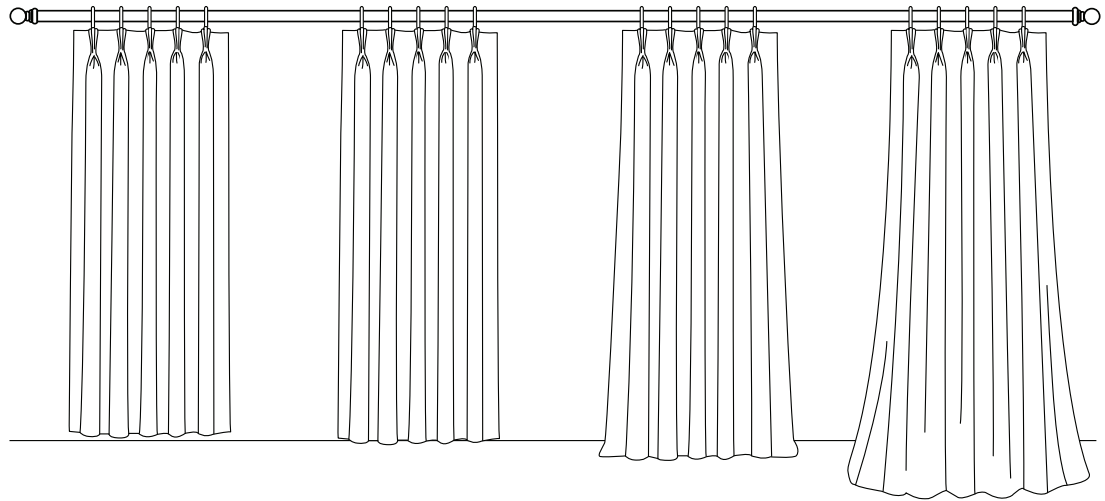

Classic
1/2" off the floor

Graze
Just touching the floor

Break
1" - 3" of extra length
spilling onto the floor

Puddle
4" - 12" of extra length
"puddling" onto the floor

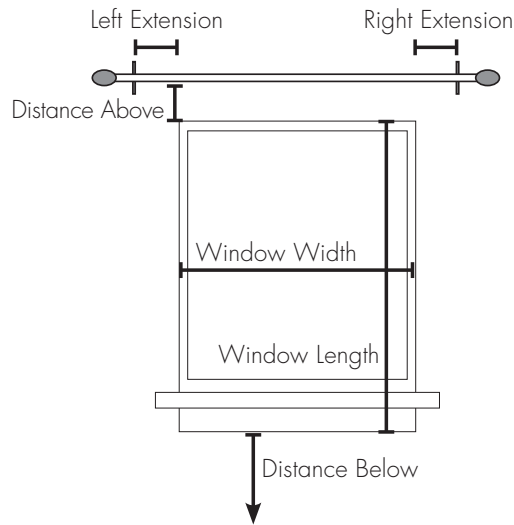

Finished Length Calculations

Distance Above Window	Window Length	Distance Below Window	Rod Takeup	Puddle or Drag	Trim	Deductions*	Finished Length
+	+	+	+	+	-	=	

*Deductions include ring hang, trims, and classic length.

Curtain Panel Yardage Chart

This yardage chart is based on 54" wide fabrics with no repeats.
(Yardage includes 3.5" return and 3.5" overlap)

Bracket to Bracket Measurement (# of fabric widths)												
measurement	Up to 18"	18"-36"	37"-56"	57"-76"	77"-96"	97"-116"	117"-136"	137"-156"	157"-176"	177"-196"		
# of widths	(1)	(2)	(3)	(4)	(5)	(6)	(7)	(8)	(9)	(10)		
Finished Length	36"	2 yds	3.75 yds	5.25 yds	7 yds	8.75 yds	10.5 yds	12.25 yds	14 yds	15.75 yds	17.5 yds	
	48"	2.25 yds	4.25 yds	6.25 yds	8.5 yds	10.5 yds	12.5 yds	14.5 yds	16.75 yds	18.75 yds	20.75 yds	
	60"	2.5 yds	5 yds	7.25 yds	9.75 yds	12.25 yds	14.5 yds	17 yds	19.25 yds	21.75 yds	24 yds	
	72"	3 yds	5.75 yds	8.25 yds	11 yds	13.75 yds	16.5 yds	19.25 yds	22 yds	24.75 yds	27.5 yds	
	84"	3.25 yds	6.25 yds	9.25 yds	12.5 yds	15.5 yds	18.5 yds	21.5 yds	24.75 yds	27.75 yds	30.75 yds	
	96"	3.5 yds	7 yds	10.25 yds	13.75 yds	17.25 yds	20.5 yds	24 yds	27.25 yds	30.75 yds	34 yds	
	108"	4 yds	7.75 yds	11.25 yds	15 yds	18.75 yds	22.5 yds	26.25 yds	30 yds	33.75 yds	37.5 yds	
	120"	4.25 yds	8.25 yds	12.25 yds	16.5 yds	20.5 yds	24.5 yds	28.75 yds	32.75 yds	36.75 yds	40.75 yds	
	132"	4.5 yds	9 yds	13.25 yds	17.75 yds	22 yds	26.5 yds	31 yds	35.25 yds	39.75 yds	44 yds	
	144"	5 yds	9.75 yds									
	156"	5.25 yds	10.25 yds									
	168"	5.5 yds	11 yds	CALL FOR INFORMATION								
	180"	6 yds	11.75 yds									
	192"	6.25 yds	12.25 yds									
204"	6.5 yds	13 yds										
220"	7 yds	13.75 yds										

If return or overlap is greater than 3.5", please call.

Curtain Panel Yardage Chart

This yardage chart is based on 54" wide up the roll fabrics with 1" - 13" repeats.
(Yardage includes 3.5" return and 3.5" overlap)

Bracket to Bracket Measurement (# of fabric widths)											
measurement	Up to 18"	18"-36"	37"-56"	57"-76"	77"-96"	97"-116"	117"-136"	137"-156"	157"-176"	177"-196"	
# of widths	(1)	(2)	(3)	(4)	(5)	(6)	(7)	(8)	(9)	(10)	
Finished Length	36"	2.25 yds	4.25 yds	6.25 yds	8.5 yds	10.5 yds	12.5 yds	14.5 yds	16.75 yds	18.75 yds	20.75 yds
	48"	2.75 yds	4.75 yds	7.25 yds	9.75 yds	12 yds	14.5 yds	16.75 yds	19.25 yds	21.75 yds	24.25 yds
	60"	3 yds	5.5 yds	8.25 yds	11 yds	13.75 yds	16.5 yds	19.25 yds	22 yds	24.75 yds	27.25 yds
	72"	3.25 yds	6.25 yds	9.25 yds	12.25 yds	15.25 yds	18.5 yds	21.5 yds	24.5 yds	27.75 yds	30.75 yds
	84"	3.75 yds	6.75 yds	10.25 yds	13.75 yds	17 yds	20.5 yds	23.75 yds	27.25 yds	30.75 yds	34.25 yds
	96"	4 yds	7.5 yds	11.25 yds	15 yds	18.75 yds	22.5 yds	26.25 yds	30 yds	33.75 yds	37.25 yds
	108"	4.25 yds	8.25 yds	12.25 yds	16.25 yds	20.25 yds	24.5 yds	28.5 yds	32.5 yds	36.75 yds	40.75 yds
	120"	4.75 yds	8.75 yds	13.25 yds	17.75 yds	22 yds	26.5 yds	30.75 yds	35.25 yds	39.75 yds	44 yds
	132"	5 yds	9.25 yds	14 yds	19 yds	23.5 yds	28.5 yds	33.25 yds	37.75 yds	42.5 yds	47.25 yds
	144"	5.25 yds	10.25 yds								
	156"	5.75 yds	10.75 yds								
	168"	6 yds	11.5 yds	CALL FOR INFORMATION							
	180"	6.25 yds	12.25 yds								
	192"	6.75 yds	12.75 yds								
204"	7 yds	13.5 yds									
220"	7.25 yds	14.25 yds									

If return or overlap is greater than 3.5", please call.

Curtain Panel Yardage Chart

This yardage chart is based on 54" wide up the roll fabrics with 14" - 27" repeats.
(Yardage includes 3.5" return and 3.5" overlap)

Bracket to Bracket Measurement (# of fabric widths)												
measurement	Up to 18"	18"-36"	37"-56"	57"-76"	77"-96"	97"-116"	117"-136"	137"-156"	157"-176"	177"-196"		
# of widths	(1)	(2)	(3)	(4)	(5)	(6)	(7)	(8)	(9)	(10)		
Finished Length	36"	2.75 yds	4.5 yds	7 yds	9.5 yds	12 yds	14.25 yds	16.75 yds	19.25 yds	21.75 yds	24.25 yds	
	48"	3 yds	5.25 yds	8 yds	10.75 yds	13.5 yds	16.25 yds	19.25 yds	22 yds	24.75 yds	27.75 yds	
	60"	3.25 yds	6 yds	9 yds	12 yds	15.25 yds	18.25 yds	21.5 yds	24.75 yds	27.75 yds	31 yds	
	72"	3.75 yds	6.5 yds	10 yds	13.5 yds	17 yds	20.25 yds	23.75 yds	27.25 yds	30.75 yds	34.25 yds	
	84"	4 yds	7.25 yds	11 yds	14.75 yds	18.5 yds	22.25 yds	26.25 yds	30 yds	33.75 yds	37.75 yds	
	96"	4.25 yds	8 yds	12 yds	16 yds	20.25 yds	24.25 yds	28.5 yds	32.75 yds	36.75 yds	41 yds	
	108"	4.75 yds	8.5 yds	13 yds	17.5 yds	22 yds	26.25 yds	30.75 yds	35.25 yds	39.75 yds	44.25 yds	
	120"	5 yds	9.25 yds	14 yds	18.75 yds	23.5 yds	28.25 yds	33.25 yds	38 yds	42.75 yds	47.75 yds	
	132"	5.25 yds	10 yds	15 yds	20 yds	25.25 yds	30.25 yds	35.5 yds	40.75 yds	45.75 yds	51 yds	
	144"	5.75 yds	10.5 yds									
	156"	6 yds	11.25 yds									
	168"	6.25 yds	12 yds	CALL FOR INFORMATION								
	180"	6.75 yds	12.5 yds									
	192"	7 yds	13.5 yds									
204"	7.25 yds	13.75 yds										
220"	7.75 yds	14.75 yds										

If return or overlap is greater than 3.5", please call.

Valance Yardage Chart

(Yardage includes 3.5" return and 3.5" overlap)

This yardage chart is based on 54" wide up the roll fabrics (with seams) with no repeats.

Finished Length	Bracket to Bracket Measurement (# of fabric widths)										
	measurement	Up to 18"	18"-36"	37"-56"	57"-76"	77"-96"	97"-116"	117"-136"	137"-156"	157"-176"	177"-196"
	# of widths	(1)	(2)	(3)	(4)	(5)	(6)	(7)	(8)	(9)	(10)
	16" (standard)	1.25 yds	2.5 yds	3.75 yds	5 yds	6 yds	7.25 yds	8.25 yds	9.5 yds	10.75 yds	12 yds
	17"-24"	1.5 yds	3 yds	4.25 yds	5.75 yds	7.25 yds	8.5 yds	10 yds	11.25 yds	12.75 yds	14 yds

This yardage chart is based on 54" wide up the roll fabrics (with seams) with 1" - 13" repeats.

Finished Length	Bracket to Bracket Measurement (# of fabric widths)										
	measurement	Up to 18"	18"-36"	37"-56"	57"-76"	77"-96"	97"-116"	117"-136"	137"-156"	157"-176"	177"-196"
	# of widths	(1)	(2)	(3)	(4)	(5)	(6)	(7)	(8)	(9)	(10)
	16" (standard)	1.75 yds	3 yds	4.5 yds	6 yds	7.5 yds	9 yds	10.5 yds	12 yds	13.5 yds	15.25 yds
	17"-24"	2 yds	3.25 yds	5 yds	6.75 yds	8.5 yds	10.25 yds	12 yds	13.75 yds	15.5 yds	17.25 yds

This yardage chart is based on 54" wide up the roll fabrics (with seams) with 14" - 27" repeats.

Finished Length	Bracket to Bracket Measurement (# of fabric widths)										
	measurement	Up to 18"	18"-36"	37"-56"	57"-76"	77"-96"	97"-116"	117"-136"	137"-156"	157"-176"	177"-196"
	# of widths	(1)	(2)	(3)	(4)	(5)	(6)	(7)	(8)	(9)	(10)
	16" (standard)	2.25 yds	3.25 yds	5.25 yds	7.25 yds	9 yds	11 yds	12.75 yds	14.75 yds	16.75 yds	18.75 yds
	17"-24"	2.5 yds	3.75 yds	5.75 yds	8 yds	10.35 yds	12.25 yds	14.5 yds	16.5 yds	18.75 yds	21 yds

Note that stripes or diamonds on up the roll fabric will have a vertical direction on the finished product. Stripes or diamonds on railroaded fabric will have a horizontal direction on the finished product. If return or overlap is greater than 3.5", please call.

This yardage chart is based on 54" wide railroaded fabrics with no repeats.

Finished Length	Bracket to Bracket Measurement (# of fabric widths)										
	measurement	Up to 18"	18"-36"	37"-56"	57"-76"	77"-96"	97"-116"	117"-136"	137"-156"	157"-176"	177"-196"
	# of widths	(1)	(2)	(3)	(4)	(5)	(6)	(7)	(8)	(9)	(10)
	16"-24"	1.75 yds	3 yds	4.5 yds	6 yds	7.25 yds	8.75 yds	10 yds	11.25 yds	12.75 yds	14.25 yds

This yardage chart is based on 54" wide railroaded fabrics with 1" - 13" repeats.

Finished Length	Bracket to Bracket Measurement (# of fabric widths)										
	measurement	Up to 18"	18"-36"	37"-56"	57"-76"	77"-96"	97"-116"	117"-136"	137"-156"	157"-176"	177"-196"
	# of widths	(1)	(2)	(3)	(4)	(5)	(6)	(7)	(8)	(9)	(10)
	16"-24"	2.25 yds	3.5 yds	4.75 yds	6.25 yds	7.75 yds	9 yds	10.5 yds	11.75 yds	13.25 yds	14.75 yds

This yardage chart is based on 54" wide railroaded fabrics with 14" - 27" repeats.

Finished Length	Bracket to Bracket Measurement (# of fabric widths)										
	measurement	Up to 18"	18"-36"	37"-56"	57"-76"	77"-96"	97"-116"	117"-136"	137"-156"	157"-176"	177"-196"
	# of widths	(1)	(2)	(3)	(4)	(5)	(6)	(7)	(8)	(9)	(10)
	16"-24"	2.5 yds	4 yds	5.25 yds	6.5 yds	8 yds	9.25 yds	10.75 yds	12.25 yds	13.5 yds	15 yds

Note that stripes or diamonds on up the roll fabric will have a horizontal direction on the finished product. Stripes or diamonds on railroaded fabric will have a vertical direction on the finished product. If return or overlap is greater than 3.5", please call.

Upgrade Yardage

For a vertical trim on a curtain panel or valance....

Length of Panel or Valance					Yardage Required (round up to nearest inch)
	+	13	=	/	36 =

For a horizontal trim on a curtain panel or valance....

# of Fabric Widths (see yardage charts)		Width of Fabric			Yardage Required (round up to nearest inch)
	x	54	=	/	36 =

For a swag (16" standard) on a 54" solid curtain panel...

# of Fabric Widths (see yardage charts)			Yardage Required (round up to nearest inch)
	x	1.25	=

For fabrics widths greater than 16", call for information. Swags are cut on the bias.

For a contrasting header on a 54" solid curtain panel...

# of Fabric Widths (see yardage charts)			Yardage Required (round up to nearest inch)
	x	.75	=

For a 22" contrasting bottom on a 54" solid curtain panel...

# of Fabric Widths (see yardage charts)			Yardage Required (round up to nearest inch)
	x	1	=

* If greater than 22", please call.



Total upgrade yardage:

Vertical Trim	Horizontal Trim	Swag	Contrasting Header	Contrasting Bottom	Vertical Band	Horizontal Band	Total Yardage Required (round up to nearest inch)
	+		+			+	=

Upgrade Yardage

For a vertical band on a curtain panel....

(based on 54" wide with no repeats and 3" band width)

		# of Bands			
Finished Length		Up to 6 bands (1)	7-12 bands (2)	13-18 bands (3)	19 or more bands (4 or more)
	36"	2 yds	3.75 yds	5.25 yds	Call for information
	48"	2.25 yds	4.25 yds	6.25 yds	
	60"	2.5 yds	5 yds	7.25 yds	
	72"	3 yds	5.75 yds	8.25 yds	
	84"	3.25 yds	6.25 yds	9.25 yds	
	96"	3.5 yds	7 yds	10.25 yds	
	108"	4 yds	7.75 yds	11.25 yds	
	120"	4.25 yds	8.25 yds	12.25 yds	
	132"	4.5 yds	9 yds	13.25 yds	
	144"	5 yds	9.75 yds	14.25 yds	
	156"	5.25 yds	10.25 yds	15.25 yds	
	168"	5.5 yds	11 yds	16.25 yds	
	180"	6 yds	11.75 yds	17.25 yds	
	192"	6.25 yds	12.25 yds	18.25 yds	
	204"	6.5 yds	13 yds	19.25 yds	
220"	7 yds	13.75 yds	20.75 yds		

For a horizontal band on a curtain panel or valance....

(based on 54" wide with no repeats and 3" band width)

Yardage	# of Bands							
	Up to 2 bands	3-4 bands	5-6 bands	7-8 bands	9-10 bands	11-12 bands	13-14 bands	15-16 bands
	1 yd	1.75 yds	2.5 yds	3.25 yds	4 yds	4.75 yds	5.5 yds	6 yds

For a combination of vertical and horizontal banding...

Formula: Yardage of Horizontal bands + Yardage of Vertical bands

Example: 2 panels per window - 20"x96" each panel - pinch pleat with 3 sided band

20" w panel = 1 width of fabric

2 horizontal bands (one on top and one on bottom) - per panel

1 vertical band per panel

per window: 4 horizontal and 2 vertical bands needed

According tables: 4 Horizontal bands - 1.75 yds

2 vertical bands - 96" L - 3.5 yds

We need: 1.75 yds + 3.5 yds = 5.25 yrs (total yardage of banding per window)

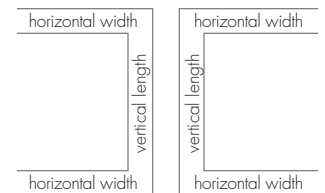

Example: 2 panels per window - 40"x120" each panel - pinch pleat with 3 sided band

40" w panel = 2 widths of fabric

4 horizontal bands (two on top and two on bottom) - per panel

1 vertical band per panel

per window: 8 horizontal and 2 vertical bands needed

According tables: 8 Horizontal bands - 3.25 yds

2 vertical bands - 120" L - 4.25 yds

We need: 3.25 yds + 4.25 yds = 7.5 yrs (total yardage of banding per panel)

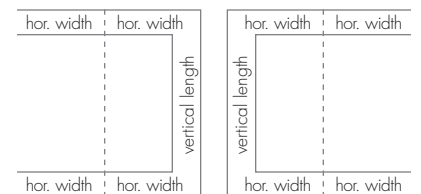

Drapery Pricing Guide*

This base pricing is for a single lined curtain panel. (Pricing will vary depending on upgrades.)

		Bracket to Bracket Measurement (# of fabric widths)									
		Up to 18" (1)	18"-36" (2)	37"-56" (3)	57"-76" (4)	77"-96" (5)	97"-116" (6)	117"-136" (7)	137"-156" (8)	157"-176" (9)	177"-196" (10)
Finished Length	Up to 120"	\$125	\$250	\$375	\$500	\$625	\$750	\$875	\$1,000	\$1,125	\$1,250
	121"-132"	\$145	\$290	\$435	\$580	\$725	\$870	\$1,015	\$1,160	\$1,305	\$1,450
	132"-144"	\$165	\$330	\$495	\$660	\$825	\$990	\$1,155	\$1,320	\$1,485	\$1,650
	144"-156"	\$185	\$370	\$555	\$740	\$925	\$1,110	\$1,295	\$1,480	\$1,665	\$1,850
	156"-168"	\$205	\$410	\$615	\$820	\$1,025	\$1,230	\$1,435	\$1,640	\$1,845	\$2,050
	168"-180"	\$225	\$450	\$675	\$900	\$1,125	\$1,350	\$1,575	\$1,800	\$2,025	\$2,250
	180"-192"	\$245	\$490	\$735	\$980	\$1,225	\$1,470	\$1,715	\$1,960	\$2,205	\$2,450

This base pricing is for a pair of lined curtain panels. (Pricing will vary depending on upgrades.)

		Bracket to Bracket Measurement				
		18"-36"	37"-76"	77"-116"	117"-156"	157"-196"
Finished Length	Up to 120"	\$250	\$500	\$750	\$1,000	\$1,250
	121"-132"	\$290	\$580	\$870	\$1,160	\$1,450
	132"-144"	\$330	\$660	\$990	\$1,320	\$1,650
	144"-156"	\$370	\$740	\$1,110	\$1,480	\$1,850
	156"-168"	\$410	\$820	\$1,230	\$1,640	\$2,050
	168"-180"	\$450	\$900	\$1,350	\$1,800	\$2,250
	180"-192"	\$490	\$980	\$1,470	\$1,960	\$2,450

This base pricing is for a single lined valance. (Pricing will vary depending on upgrades.)

		Bracket to Bracket Measurement (# of fabric widths)									
		Up to 18" (1)	18"-36" (2)	37"-56" (3)	57"-76" (4)	77"-96" (5)	97"-116" (6)	117"-136" (7)	137"-156" (8)	157"-176" (9)	177"-196" (10)
Finished Length	16"-24"	\$95	\$190	\$285	\$380	\$475	\$570	\$665	\$760	\$855	\$950

*Price includes 100% cotton medium-weight drapery lining.

Upgrade Pricing Guide

Vertical Trims (panel length)

	Upgrade Charges
A. Add Vertical Trim to Leading Edge	\$8 per yard (Example: 96" length/36=2.6x\$8=\$21)
D. Add Vertical Band to Leading Edge*	\$15 per yard
G. Add Vertical Trim	\$8 per yard

* See page 17 to determine total number of banding widths

Horizontal Trims (fabric width) 54" Fabric Width (54" = 1.5 yards)

	Upgrade Charges
B. Add Horizontal Trim to Top Edge	\$15 per width
C. Add Horizontal Trim to Bottom Edge	\$15 per width
E. Add Horizontal Band to Bottom Edge*	\$20 per width
H. Add Horizontal Trim	\$15 per width
J. Add 2 Rows of Trim	\$30 per width
K. Add 3 Rows of Trim	\$45 per width
L. Add Button to Pleat	\$15 per width (5 Buttons)
M. Add Swagged Cord with Tassels	\$15 per width

* See page 17 to determine total number of banding widths

Mitered Trims

	Upgrade Charges
F. Add 3-Sided Mitered Band	\$15 per yard (Vertical) + \$20 per width (Horizontal)
I. Add 3-Sided Mitered Trim	\$8 per yard (Vertical) + \$15 per width (Horizontal)

Contrast Pieces

	Upgrade Charges
P. Add Contrasting Header	\$20 per width
Q. Add Contrasting Bottom	\$20 per width

Attached Items

	Upgrade Charges
N. Add Attached Valance	\$20 each (Price does not include the actual valance)
O. Add Attached Swag	\$20 each (Price does not include the actual swag)

Other

	Upgrade Charges
R. Deduct Lining - Unlined	- \$10 per width
S. Add Interlining	\$20 per width
T. Add Blackout Lining	\$20 per width
U. Grommets	\$50 per width

Pleated Curtain Panel Styles (p. 24)

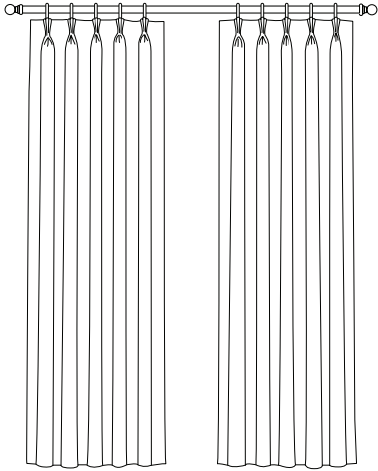

Pinch Pleat

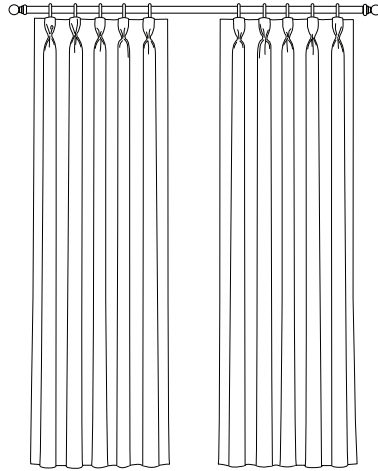

Goblet Pleat

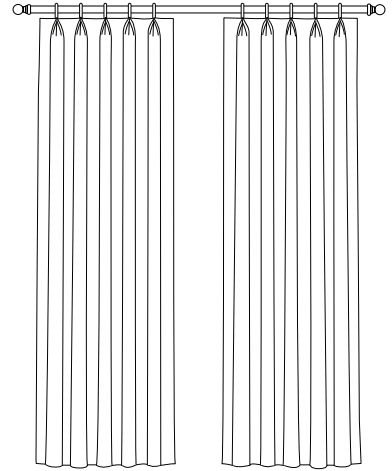

Parisian Pleat

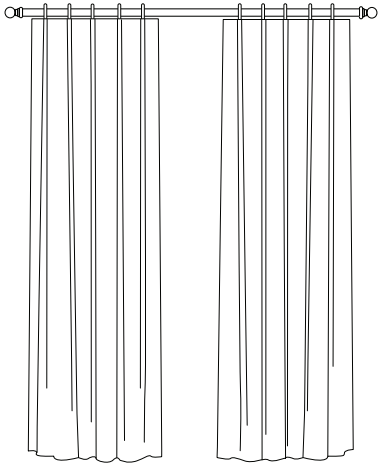

Single Pleat

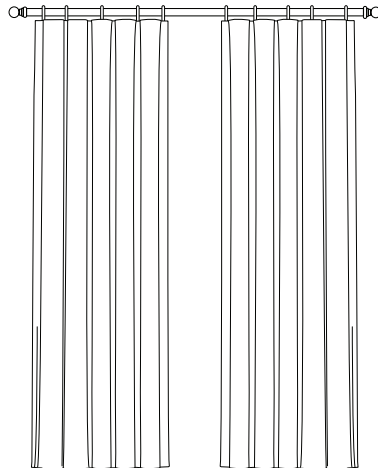

Box Pleat

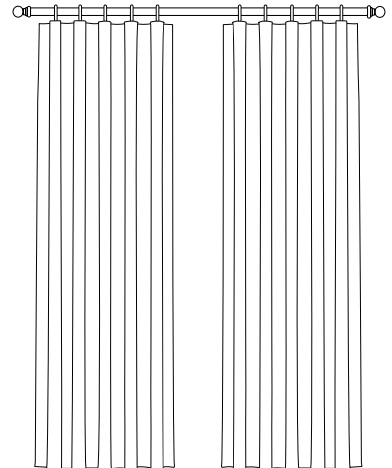

Cartridge Pleat

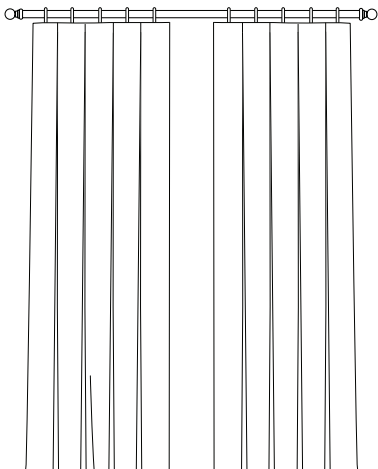

Inverted Pleat

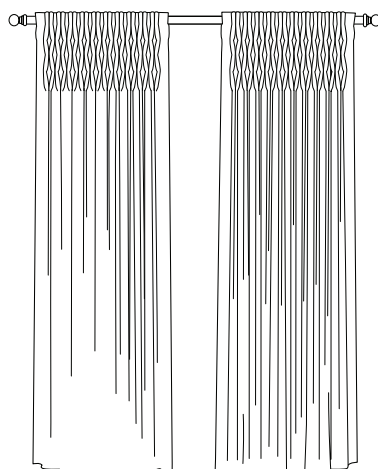

Diamond-Smocked Pleat

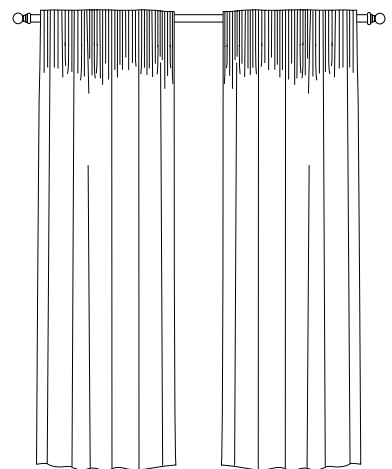

Smocked Pencil Pleat

Flat Curtain Panel Styles (p. 24)

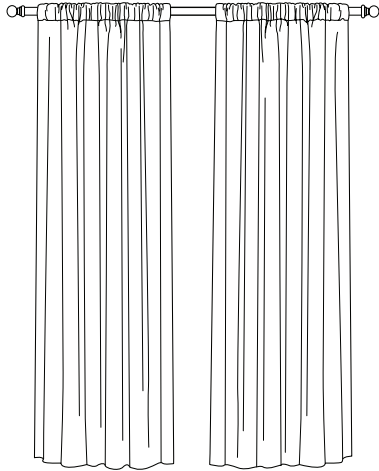

Rod Pocket

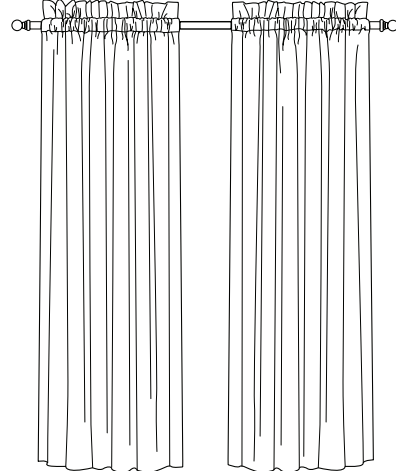

Rod Pocket with Header

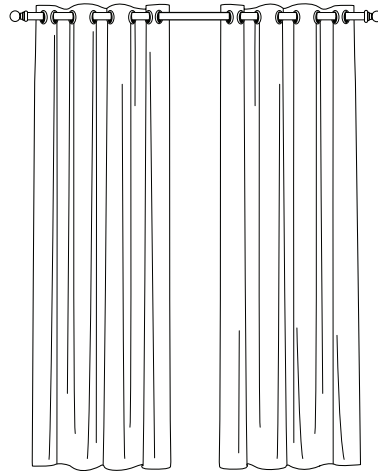

Grommet

Valance Styles (p. 26)

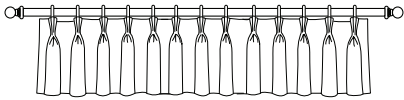

Pinch Pleat

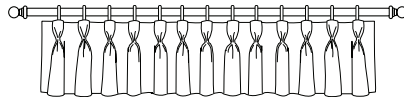

Goblet Pleat

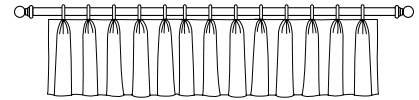

Parisian Pleat

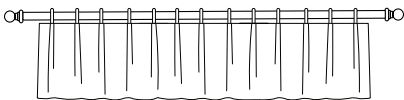

Single Pleat

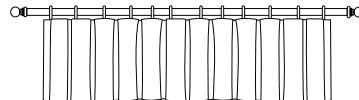

Box Pleat

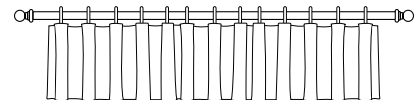

Cartridge Pleat

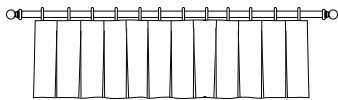

Inverted Pleat

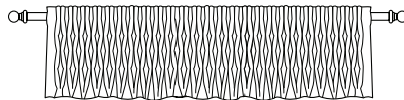

Diamond-Smocked Pleat

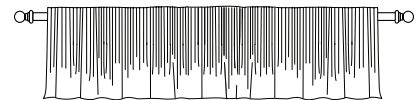

Smocked Pencil Pleat

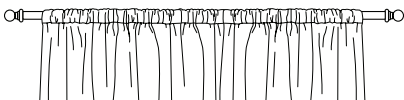

Rod Pocket



Rod Pocket with Header



Grommet

Shower Curtain Styles (p. 28)

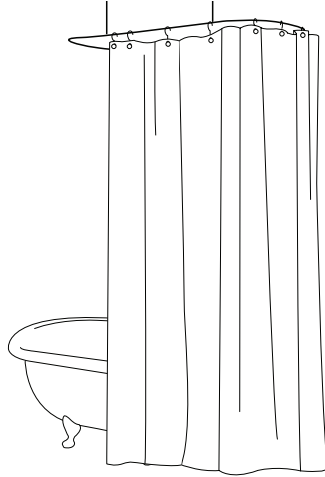

Shower Curtain
with Grommets (3/4")

Curtain Panel (lined)

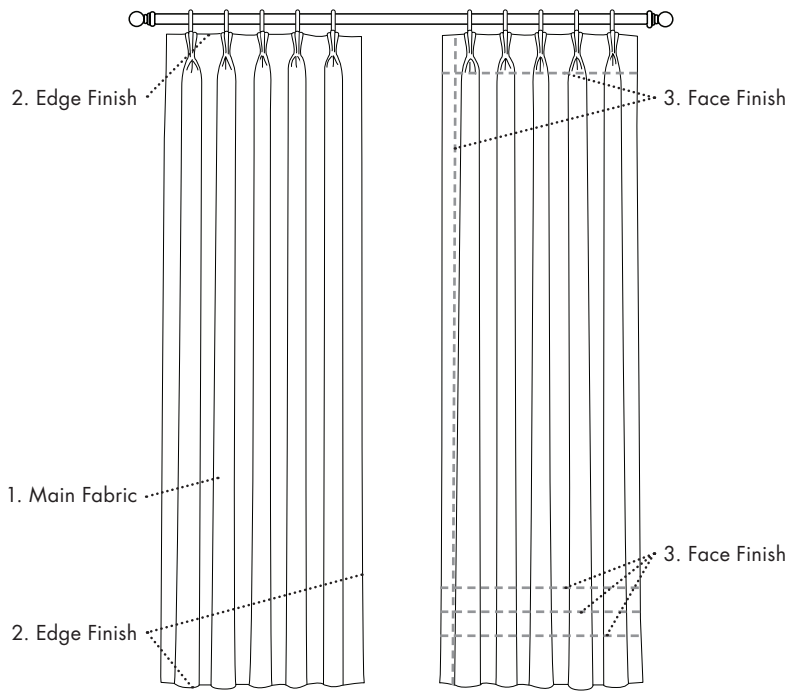

Upgrade Options (per width)

Edge Finish

- A. Add Vertical Trim to Leading Edge (p.30)
- B. Add Horizontal Trim to Top Edge (p.30)
- C. Add Horizontal Trim to Bottom Edge (p.30)
- D. Add Vertical Band to Leading Edge (p.30)
- E. Add Horizontal Band to Bottom Edge (p.30)
- F. Add 3-Sided Mitered Band (p.30)

Face Finish

- G. Add Vertical Trim (p.31)
- H. Add Horizontal Trim (p.31)
- I. Add 3-Sided Mitered Trim (p.31)
- J. Add 2 Rows of Trim (p.31)
- K. Add 3 Rows of Trim (p.31)
- L. Add Button to Pleat (p.31)
- M. Add Swagged Cord with Tassels (p.31)
- N. Add Attached Valance (p.32)
- O. Add Attached Swag (p.32)
- P. Add Contrasting Header (p.32)
- Q. Add 22" Contrasting Bottom (p.32)

Other

- R. Deduct Lining - Unlined
- S. Add Interlining
- T. Add Blackout Lining
- U. Grommets

* Up to 120" long. See chart on page 19 for pricing.

Finished Width & Length Calculations

Finished Width (see page 8-9)

Single Stationary or Side Panels

To help determine the size of your stationary panel, use chart below.

Left Extension	Window Width	Right Extension	Bracket to Bracket	Divide by 4	Finished Width per panel
+	+	=	/	4 =	

Functional Panels (split draw)

Left Extension	Window Width	Right Extension	Bracket to Bracket	Return	Overlap	Overall Finished Width
+	+	=	+	L R	+	L R =

Single Functional Panel (one way draw)

Left Extension	Window Width	Right Extension	Bracket to Bracket	Return	Overlap	Left or Right Stacking (facing window)	Finished Width
+	+	=	+	L or R	+	<input type="checkbox"/> L <input type="checkbox"/> R =	

1" width finishes to 20" (if less than 20", please call)
For finished width round up to nearest width

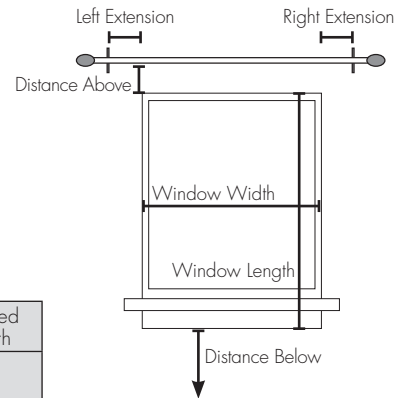

Finished Length (see page 10-11)

Allowances

Distance Above Window	Window Length	Distance Below Window	Rod Takeup	Puddle or Drag	Trim	Deductions (see page 10)	Finished Length
+	+	+	+	+	-	=	

Calculate Your Custom Product Cost (see page 18-19)

Base and Upgrade Charges	Material Cost	Total Cost
Base Charge: \$ _____	Face Fabric Cost: \$ _____	= \$ _____
Edge Finish Upgrade Charges: \$ _____	Edge Finish Cost: \$ _____	
Face Finish Upgrade Charges: \$ _____	Face Finish Cost: \$ _____	
	Other Cost: \$ _____	

Curtain Panel (lined)

Choose Style: Pinch Pleat Goblet Pleat Parisian Pleat Single Pleat Box Pleat
(See pages 20-21) Cartridge Pleat Inverted Pleat Diamond-Smocked Pleat Smocked Pencil Pleat Rod Pocket
 Rod Pocket with Header Grommet (see upgrade "U")

Choose Quantity: _____ Left Panel Right Panel Pair(s)

Choose Width*: Finished Width: _____ " *For oversized panels (over 196" bracket to bracket width), please call.

Choose Length*: Finished Length: _____ " *For oversized panels (over 132" length finished), please call.

Choose Fabric:

1. Main Fabric: Fabric Vendor: Eastern Accents C.O.M. (Vendor Name: _____)
Fabric Code: _____ Railroaded Up the Roll/Solid
Fabric Width: _____ " Repeat: V: _____ " H: _____ " Yardage Needed (see p. 12): _____ yds

Add Upgrades (optional):

2. Edge Finish: A: Add Vertical Trim to Leading Edge B: Add Horizontal Trim to Top Edge C: Add Horizontal Trim to Bottom Edge
 D: Add Vertical Band to Leading Edge E: Add Horizontal Band to Bottom Edge F: Add 3-Sided Mitered Band

Edge Trim (Upgrade A, B, and C):

Trim Vendor: Eastern Accents C.O.M. (Vendor Name: _____)
Trim Code: _____ Yardage Needed (see p. 16-17): _____ yds

Edge Fabric (Upgrade D, E, and F):

Fabric Vendor: Eastern Accents C.O.M. (Vendor Name: _____)
Fabric Code: _____ Railroaded Up the Roll/Solid
Fabric Width: _____ " Repeat: V: _____ " H: _____ " Yardage Needed (see p. 16-17): _____ yds

3. Face Finish: G: Add Vertical Trim H: Add Horizontal Trim I: Add 3-Sided Mitered Trim J: Add 2 Rows of Trim
 K: Add 3 Rows of Trim L: Add Button on Pleat M: Add Swagged Cord with Tassels N: Add Attached Valance (see p. 22)
 O: Add Attached Swag (see p. 24) P: Contrasting Header Q: Add 22" Contrasting Bottom

Face Trim (Upgrade G, H, I, J, K, L, and M):

Trim Vendor: Eastern Accents C.O.M. (Vendor Name: _____)
Trim Code: _____ Yardage Needed (see p. 16-17): _____ yds

Face Fabric (Upgrade L, N, O, P and Q):

Fabric Vendor: Eastern Accents C.O.M. (Vendor Name: _____)
Fabric Code: _____ Railroaded Up the Roll/Solid
Fabric Width: _____ " Repeat: V: _____ " H: _____ " Yardage Needed (see p. 16-17): _____ yds

Other Upgrades: R: Deduct Lining - Unlined S: Add Interlining T: Add Blackout Lining U: Grommets

Lining Fabric: White Ivory Putty

Grommets**: Antique Brass Antique Copper Black Brushed Nickel Satin Smoke

*Go to page 12 to see yardage requirement chart.
**See grommet finishes at EasternAccents.com

Special Instructions:

To place your order, please sign below and email/fax both pages of worksheet to: Custom@EasternAccents.com/800.998.3278.

Company Name: _____ Account #: _____

Phone: _____ Fax: _____ Email: _____

Signature: _____ Date: _____

Custom items cannot be exchanged and are non-returnable and non-refundable.

Valance (lined)

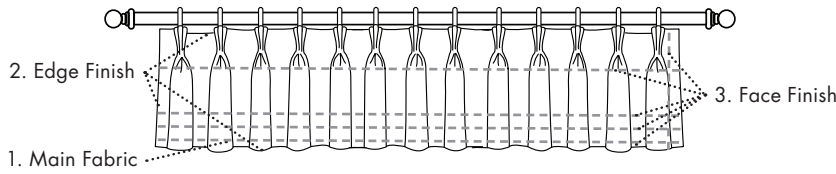

Upgrade Options (per width)

Edge Finish

- B. Add Horizontal Trim to Top Edge (p.30)
- C. Add Horizontal Trim to Bottom Edge (p.30)
- E. Add Horizontal Band to Bottom Edge (p.30)
- F. Add 3-Sided Mitered Band (p.30)

Face Finish

- H. Add Horizontal Trim (p.31)
- I. Add 3-Sided Mitered Trim (p.31)
- J. Add 2 Rows of Trim (p.31)
- K. Add 3 Rows of Trim (p.31)
- L. Add Button to Pleat (p.31)

Other

- R. Deduct Lining - Unlined
- S. Add Interlining
- T. Add Blackout Lining
- U. Grommets

* Up to 18" width. See chart on page 19 for other pricing.

Finished Width & Length Calculations

Finished Width (see page 8-9)

Left Extension	Window Width	Right Extension	Bracket to Bracket	Return	Finished Width
+	+	=	+	L R	=

1" width finishes to 20" (if less than 20", please call)
For finished width round up to nearest width

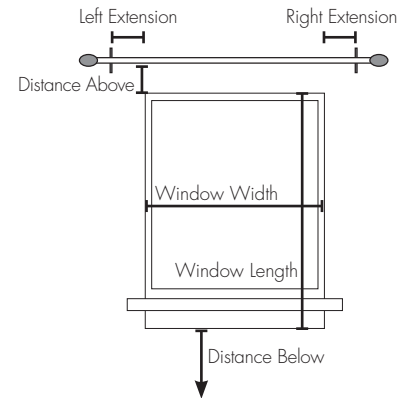

Finished Length (see page 10-11) Allowances

Distance Above Window	1/4 of Window Length (approx.)	Rod Takeup	Trim	Deductions (see page 10)	Finished Length
+	+	+	-	=	

Calculate Your Custom Product Cost (see page 18-19)

Base and Upgrade Charges	Material Cost	Total Cost
Base Charge: \$ _____	Face Fabric Cost: \$ _____	= \$ _____
Edge Finish Upgrade Charges: \$ _____	Edge Finish Cost: \$ _____	
Face Finish Upgrade Charges: \$ _____	Face Finish Cost: \$ _____	
	Other Cost: \$ _____	

Valance (lined)

Choose Style: Pinch Pleat Goblet Pleat Parisian Pleat Single Pleat Box Pleat
 (See page 20) Cartridge Pleat Inverted Pleat Diamond-Smocked Pleat Smocked Pencil Pleat
 Rod Pocket* Rod Pocket with Header* Grommet (see upgrade "U")*

*Make sure to include x2.5 fullness when using flat panel options.

Choose Quantity: _____

Choose Width*: Finished Width: _____ " *For oversized valances (over 196" bracket to bracket width), please call.

Choose Length*: Finished Length: _____ " Standard 16"

Choose Fabric:

1. Main Fabric: Fabric Vendor: Eastern Accents C.O.M. (Vendor Name: _____)
 Fabric Code: _____ Railroaded Up the Roll/Solid
 Fabric Width: _____ " Repeat: V: _____ " H: _____ " Yardage Needed (see p. 15): _____ yds

Add Upgrades (optional):

2. Edge Finish: B: Add Horizontal Trim to Top Edge C: Add Horizontal Trim to Bottom Edge E: Add Horizontal Band to Bottom Edge
 F: Add 3-Sided Mitered Band

Edge Trim (Upgrade B and C):

Trim Vendor: Eastern Accents C.O.M. (Vendor Name: _____)
 Trim Code: _____ Yardage Needed (see p. 16-17): _____ yds

Edge Fabric (Upgrade E and F):

Fabric Vendor: Eastern Accents C.O.M. (Vendor Name: _____)
 Fabric Code: _____ Railroaded Up the Roll/Solid
 Fabric Width: _____ " Repeat: V: _____ " H: _____ " Yardage Needed (see p. 16-17): _____ yds

3. Face Finish: H: Add Horizontal Trim I: Add 3-Sided Mitered Trim J: Add 2 Rows of Trim K: Add 3 Rows of Trim
 L: Add Button on Pleat

Face Trim (Upgrade H, I, J, K, and L):

Trim Vendor: Eastern Accents C.O.M. (Vendor Name: _____)
 Trim Code: _____ Yardage Needed (see p. 16-17): _____ yds

Face Fabric (Upgrade I):

Fabric Vendor: Eastern Accents C.O.M. (Vendor Name: _____)
 Fabric Code: _____ Railroaded Up the Roll/Solid
 Fabric Width: _____ " Repeat: V: _____ " H: _____ " Yardage Needed (see p. 16-17): _____ yds

Other Upgrades: R: Deduct Lining - Unlined S: Add Interlining T: Add Blackout Lining U: Grommets

Lining Fabric: White Ivory Putty

Grommets:** Antique Brass Antique Copper Black Brushed Nickel Satin Smoke

*Go to page 15 to see yardage requirement chart.
 **See grommet finishes at EasternAccents.com

Special Instructions:



To place your order, please sign below and email/fax both pages of worksheet to: Custom@EasternAccents.com/800.998.3278.

Company Name: _____ Account #: _____

Phone: _____ Fax: _____ Email: _____

Signature: _____ Date: _____

Custom items cannot be exchanged and are non-returnable and non-refundable.

Shower Curtain with Grommets (3/4" nickel grommets, lined)

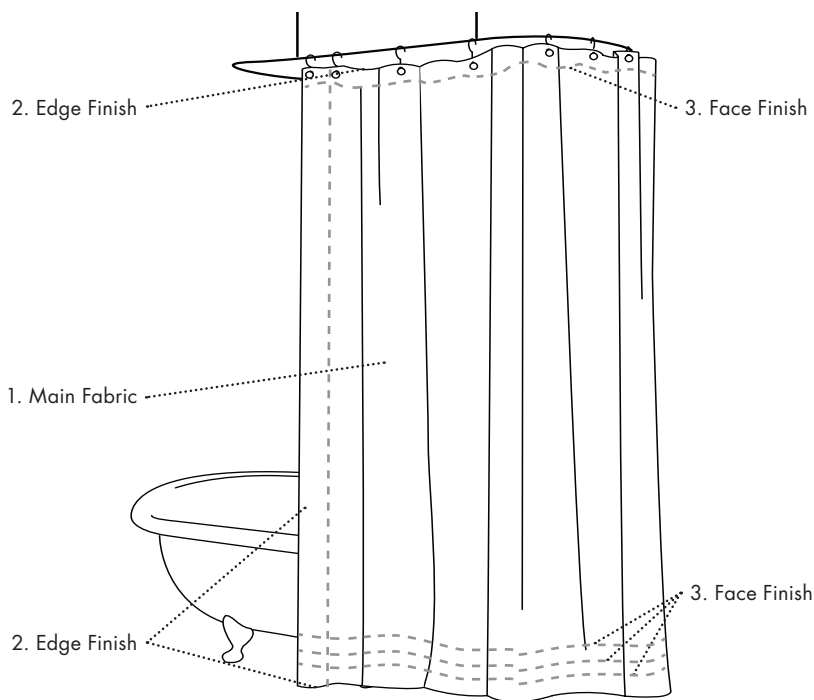

Base Charge: \$155

Upgrade Options (per width)

Edge Finish

- A. Add Vertical Trim to Leading Edge (p.30)
- B. Add Horizontal Trim to Top Edge (p.30)
- C. Add Horizontal Trim to Bottom Edge (p.30)
- D. Add Vertical Band to Leading Edge (p.30)
- E. Add Horizontal Band to Bottom Edge (p.30)
- F. Add 3-Sided Mitered Band (p.30)

Face Finish

- G. Add Vertical Trim (p.31)
- H. Add Horizontal Trim (p.31)
- I. Add 3-Sided Mitered Trim (p.31)
- J. Add 2 Rows of Trim (p.31)
- K. Add 3 Rows of Trim (p.31)
- P. Add Contrasting Header (p.32)
- Q. Add 22" Contrasting Bottom (p.32)

Other

- R. Deduct Lining - Unlined

See chart on page 19 for other pricing.

Calculate Your Custom Product Cost (see page 18-19)

Base and Upgrade Charges	+	Material Cost	=	Total Cost
Base Charge: \$155		Face Fabric Cost: \$ _____		\$ _____
Edge Finish Upgrade Charges: \$ _____		Edge Finish Cost: \$ _____		
Face Finish Upgrade Charges: \$ _____		Face Finish Cost: \$ _____		
		Other Cost: \$ _____		

Fabric Yardage Requirements

	Yardage
Solid 54" Fabric	5.5 yds
Up to 13" Repeat	6 yds
14" - 27" Repeat	6.5 yds

Trim Yardage Requirements

	Yardage
Vertical	Length + 11"/36 = _____
Horizontal	Width + 5" x # of rows/36 = _____

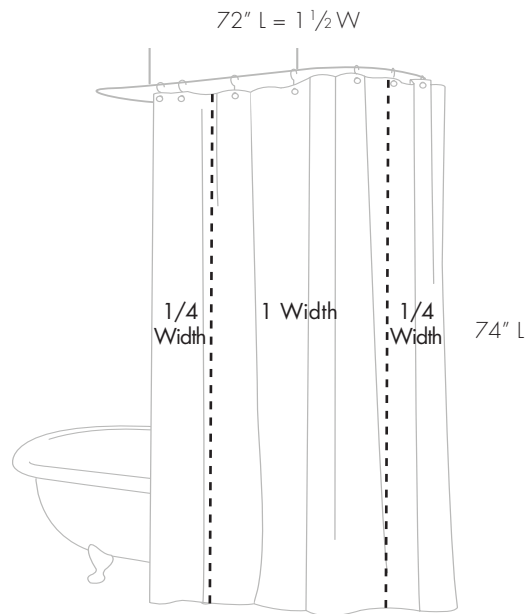

Shower Curtain (lined)

Choose Quantity: _____

Choose Width: Standard 72" Call for custom sizes

Choose Length: Standard 74" Call for custom sizes

Choose Direction*: Left Facing Right Facing *When choosing vertical trim or band

Choose Fabric:

1. Main Fabric: Fabric Vendor: Eastern Accents C.O.M. (Vendor Name: _____)
Fabric Code: _____ Railroaded Up the Roll/Solid
Fabric Width: _____" Repeat: V: _____" H: _____" Yardage Needed: _____ yds

Add Upgrades (optional):

2. Edge Finish: A: Add Vertical Trim to Leading Edge B: Add Horizontal Trim to Top Edge C: Add Horizontal Trim to Bottom Edge
 D: Add Vertical Band to Leading Edge E: Add Horizontal Band to Bottom Edge F: Add 3-Sided Mitered Band

Edge Trim (Upgrade A, B, and C):

Trim Vendor: Eastern Accents C.O.M. (Vendor Name: _____)
Trim Code: _____ Yardage Needed: _____ yds

Edge Fabric (Upgrade D, E, and F):

Fabric Vendor: Eastern Accents C.O.M. (Vendor Name: _____)
Fabric Code: _____ Railroaded Up the Roll/Solid
Fabric Width: _____" Repeat: V: _____" H: _____" Yardage Needed: _____ yds

3. Face Finish: G: Add Vertical Trim H: Add Horizontal Trim I: Add 3-Sided Mitered Trim J: Add 2 Rows of Trim
 K: Add 3 Rows of Trim P: Contrasting Header Q: Add Contrasting Bottom

Face Trim (Upgrade G, H, I, J, and K):

Trim Vendor: Eastern Accents C.O.M. (Vendor Name: _____)
Trim Code: _____ Yardage Needed: _____ yds

Face Fabric (Upgrade P and Q):

Fabric Vendor: Eastern Accents C.O.M. (Vendor Name: _____)
Fabric Code: _____ Railroaded Up the Roll/Solid
Fabric Width: _____" Repeat: V: _____" H: _____" Yardage Needed: _____ yds

Other Upgrades: R: Deduct Lining - Unlined

Special Instructions:

To place your order, please sign below and email/fax both pages of worksheet to: Custom@EasternAccents.com/800.998.3278.

Company Name: _____ Account #: _____

Phone: _____ Fax: _____ Email: _____

Signature: _____ Date: _____

Custom items cannot be exchanged and are non-returnable and non-refundable.

Drapery Upgrades

Edge Finish Upgrades

A. Add Vertical Trim to Leading Edge

To make your panel unique or finish off the overall style, add any trim to the leading edge of the panel.



D. Add Vertical Band to Leading Edge

Make your curtain panels distinctly yours by adding a sophisticated vertical 3" band. This upgrade involves adding a single vertical 3" band to a single curtain panel.



B. Add Horizontal Trim to Top Edge

Add flair to the very top edge of the panel by adding any type or style of trim.



E. Add Horizontal Band to Bottom Edge

A 3" horizontal band is a chic way of incorporating a contrasting fabric or color in your panel design. This upgrade involves adding a single, 3" horizontal band to a single curtain panel. Our standard is to place the band at the bottom edge of the panel.



C. Add Horizontal Trim to Bottom Edge

Adding any type or style of trim to the very bottom edge can make panels stand out with your own decorative touch.



F. Add 3-Sided Mitered Band

A 3-sided mitered band is a striking accent that works especially well with flat panel styles. Please note this upgrade is a 3" band applied to the top, leading vertical edge, and the bottom of a single curtain panel, with the band fabric mitered at the two corners.



Drapery Upgrades

Face Finish Upgrades

G. Add Vertical Trim

This upgrade involves adding a single vertical trim to a single curtain panel. Our standard is to place the trim 3" inset from the leading edge.



H. Add Horizontal Trim

Horizontal trimming can add the perfect touch to the top of a panel or can emphasize the graceful folds at the bottom of a panel. This upgrade involves adding a single horizontal trim to a single curtain panel. Our standard is to place the trim at 4" above the bottom edge or just below the pinch line on top.

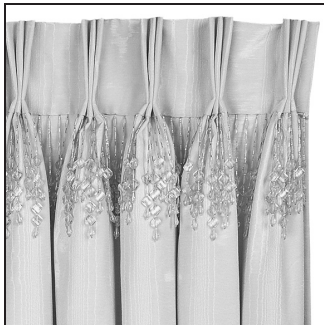

I. Add 3-Sided Mitered Trim

A 3-sided mitered trim will delicately define and frame your panel. This upgrade involves adding a 3-sided mitered trim to a single curtain panel. Our 3-sided mitered trim is applied to the top leading vertical edge and bottom of a single panel, with the trim sewn together diagonally at two corners. Our standard is to place trim at a 3" inset from all outside edges.



J. & K. Add 2 or 3 Rows of Trim Enhance your panels by incorporating two or three rows of horizontal trimming at the bottom of your panel. Our standard is to place these rows of trim approximately 6" apart and they are located about 4" from the bottom of the panel.



L. Add Button to Pleat For a unique decorative touch, you may add buttons at the pinch line of your curtain panel.



M. Add Swagged Cord with Tassels

For a truly decadent touch, add a formal swagged cord with tassels to your pleated panel. In this upgrade, a cord is sewn to your panel at the pleat line, with the cord's tasseled ends draping gracefully down each side of the panel. Our standard is one swag per width.

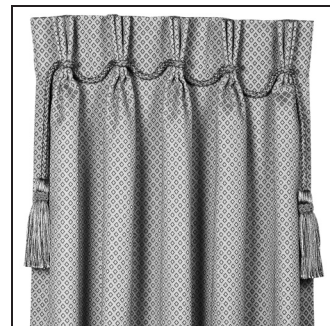

Drapery Upgrades

Face Finish Upgrades

N. Add Attached Valance

For a stunning silhouette, add a valance style that is attached to the panel.



P. Add Contrasting Header

Add an eye-catching touch to your panels with a header in contrasting fabric. This style involves adding a different railroaded fabric for the header portion of the panel, resulting in a striking, well-defined curtain panel.



O. Add Attached Swag

Add a swag style that is attached to the panel for a dramatic touch.

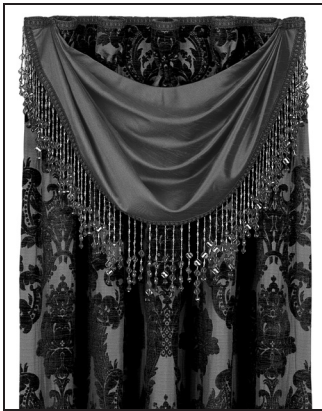

Q. Add 22" Contrasting Bottom

This popular style gives you the opportunity to incorporate a second color or railroaded fabric in your curtain design.





Cortina Tassel Tiebacks

Cortina Tassel Tiebacks

Acorn	TCU-01	\$34
Antique	TCU-02	\$34
Aqua	TCU-03	\$34
Claret	TCU-04	\$34
Marble	TCU-05	\$34
Petal	TCU-06	\$34
Pewter	TCU-07	\$34
Umber	TCU-08	\$34

Cortina Measurements

The overall dimension of the tieback is 32" – this is the length from the top of the cord to the bottom of the tassel. The tassel length is 11" and the cord diameter is 3/8". The cord's embrace (or spread) is 36" – this is the length of cord that ties around your curtain panel.

Overall Dimension	32"
Tassel Length	11"
Cord Diameter	3/8"
Embrace	36"

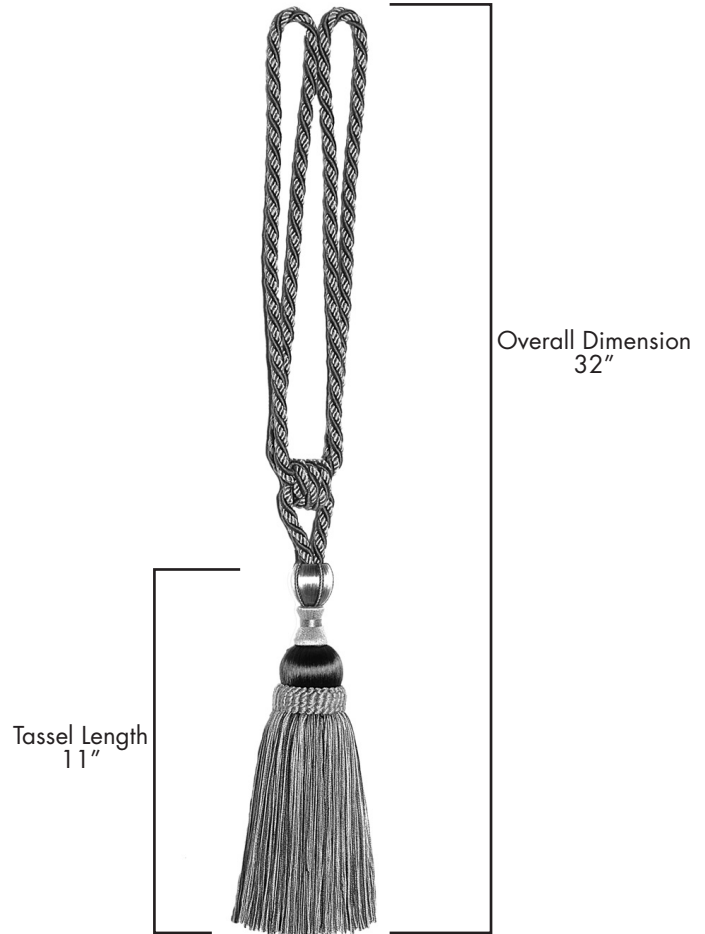

Embrace
36"



Window Hardware Collections

Art Meets Functionality



Metallique Collection



Couture Banana Bark Collection



Gemelma Collection



Couture Capiz Shell Collection

Complement your C.O.M. drapery products with any of the stunning EA Window hardware collections.

A marriage of craftsmanship and style, the hardware is available in seven finishes, including exquisite hand-applied Couture Capiz Shell and Couture Banana Bark. Visit EAWindow.com or call for more information.



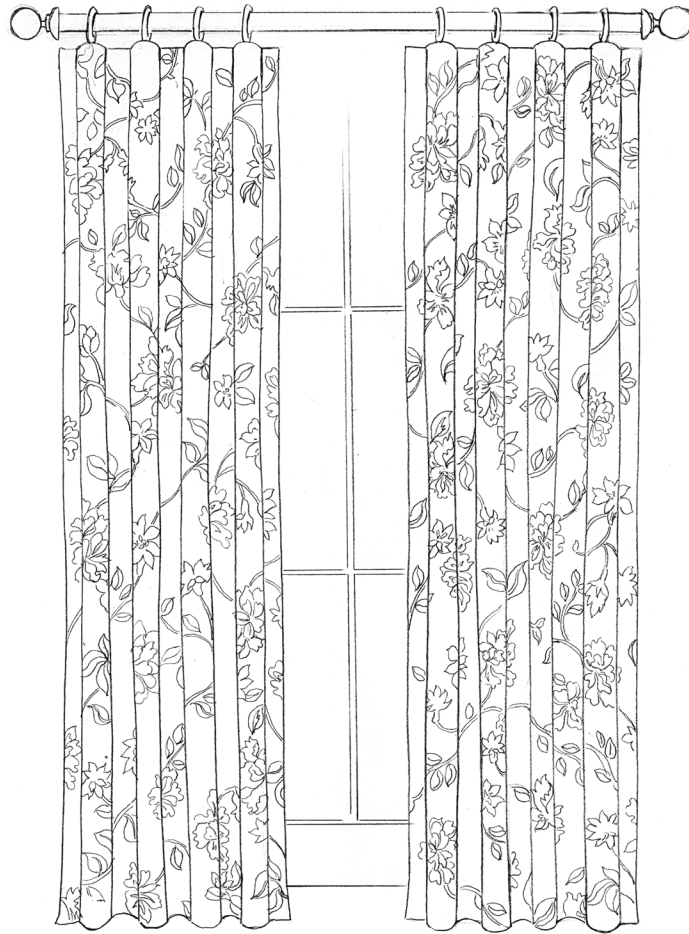

E a s t e r n  *A c c e n t s*®

Phone: 800.397.4556 • Fax: 800.998.3278 • EasternAccents.com/Design

PL-COD-ST0510